

The M6 OEM Radio Modem is low-cost rugged single-board 2W VHF/UHF/800MHz narrow-band OEM data radio modem with digital serial interface. Ideal for Automatic Meter Reading (AMR), SCADA and telemetry applications. It is over-the-air compatible with Raveon's 5-watt M7 and M8 series of data radios.



Preliminary Product Overview

Long-Range Operation

Operating in the narrow-band frequency bands, the RV-M6 radio modem works over 10 miles point-to-point and many miles with omni-directional antennas. All RV-M6 modems support store-and-forward repeating for wide-area coverage.

GPS Option

The optional internal GPS allows the RV-M6 to be a powerful Automatic Vehicle Locating (AVL) system or Time Space Position Information (TSPI) reporting device. Raveon's TDMA protocol is built in for track thousands of things in real time.

Tech Series I/O Options

The M50 may be installed in a Raveon M22 Tech Series enclosure with these I/O options. The following interface boards may be attached or changed at any time:

- RS-232 [S]
- USB [U]
- RS-485 [T]
- RS-422 [F]
- GPIO [G]
- Bluetooth [B]



High Speed and High Efficiency

The RV-M6 operates with user-selectable over-the-air data rates of 1200 to 19200bps. Its fast-switching radio enables it to send up to 50 transmissions per second.

Wireless SCADA RTU

When used with the GPIO interface in the Tech Series enclosures, or just using the M6's TTL IO pins,

it implements many SCAD remote terminal unit features.

Flexible Input Voltage

The RV-M6 is designed to run off of voltage sources such as 7V-30V. For other voltage ranges, contact the factory.

Automatic Meter Reading

Being small, power efficient, and fast makes the M6 ideal for automatic meter reading. With a communication range of many miles, a network of M6 radios can cover a nation reading and managing a smart grid.

Spectrally Efficient

In the USA, FCC complaint data radios must be capable of 9600baud in 12.5kHz channel or 19200baud in 25kHz channel. The M6's 4FSK modes meet all FCC spectral efficiency requirements.

Network Management

The CPU in the M6 has many features and command implemented in it to make setting up and managing large radio networks very easy. 16 bit IDs, ID masks, packet filtering, and repeating by ID are some powerful features. Ping by ID capability and remote command execution simply network monitoring and diagnostics.

Very Low Power Consumption

It has very low power consumption, and sleep modes allow it to be active and consume almost no power at all.

Universal 20-Pin Header

The M6 is plug-in compatible with Raveon's M8, M50, and Z50 giving your design the ability to use 3G cellular, 915MHz ISM LoRa, industrial VHF, UHF, 220MHz, or the M6.

Frequency Stability

Better than $\pm 1.5\text{ppm}$

General Specifications

Model:

RV-M6c-xx-oo (x=band)(oo=options)

Size:

61mm X 37mm

Weight:

3 oz

Input Voltage:

Clean Regulated 7-30V DC.
(Max ripple 50mV AC)

Current Draw, (12.5V DC):

Receiving data: <58mA
1W/2W transmitting: < 400mA/600mA
Sleep ATSM2 (<45mA) (RX disabled)
GPS Option: adds 8mA average, 20mA Acqui.

Frequency Bands:

VA 135-155MHz
VM MURS channels
VB 150-174MHz
UC 450-470MHz

Contact factory for use in other 130MHz - 990MHz

Options: (c)

Standard transceiver: S
Internal GPS G
Receive Only R

Serial Port Baud Rates (programmable)

1.2k, 2.4k, 4.8k, 9.6k, 19.2k, 38.4k, 57.6k, 115.2k

Over-the-air baud rates (programmable)

-N 1200, 2000, 2400, 4.8k, 5142, 8K,9.6k
-W 1200, 2000, 2400, 4.8k, 8k, 9.6k, 19.2k

Full Spec Operating Temperature range

-30°C to +60°C

TX-RX and RX-TX turn-around time

<3mS

RF I/O Connector

MMCX (Female)

LED Indications: TX, RX

Transmitter Specifications

RF Power Output 2W

(Lower power options available)

Maximum Duty Cycle 100% to 40C, 25% to 60C
Frequency Deviation $\pm 2.2\text{kHz} (-N) \pm 3.5\text{kHz} (-W)$
TX Spurious outputs < -70dBc
Occupied Bandwidth per FCC
FCC Emissions Designator 11K0F1D (-N)

Receiver Specifications

RX sensitivity (.1% BER)

9600bps < -108dBm

4800bps < -114dBm

1200 & 2400baud

< -118dBm

RF No-tune bandwidth

20MHz

Adjacent Channel Selectivity 12.5kHz.....-50dB

Adjacent Channel Selectivity 25kHz.....-60dB

Alternate Channel Selectivity-65dB

Blocking and spurious rejection 10MHz .-85dB

RX intermodulation rejection.....-70dB

Input / Output Connection Functions

20-Pin Interface Port

1	GND	Ground
2	VCC	DC Input
3	CD	Carrier Detect Out.
4	TX On	Pin is High when module is transmitting. Low when off, receiving, or sleeping.
5	Data In (TXD)	Transmit serial data input.
6	Data Out (RXD)	Receive serial data output.
7	Enable	Low to shut-down the module. High to enable it.
8	DTR	CPU Sleep input. Put in low-power fast-startup mode.
9	CTS	Clear to send output. Indicates state of internal buffers.
10	RTS	RTS input for serial flow control.
11		
12	VDIG	3.3V output
13	IOA	IO port A, Analog Input Capability.
14	IOB	IO port B,
15	IOC	IO port C
16	STAT1	Status IO 1
17		Do not connect.
18	STAT2	Status LED out
19	GND	Ground
20		Do not Connect

Mechanical Specifications

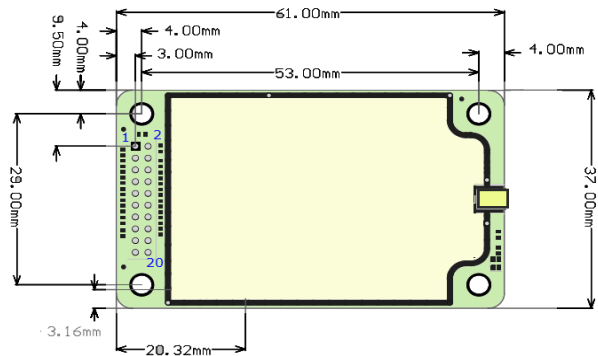

Raveon Technologies Corporation

2320 Cousteau Court
Vista, CA 92081 - USA
Phone: +1-760-444-5995

Version A3

Email: sales@raveon.com

Fax: +1-760-444-5997

SCADA and Remote Control Features

Build into the M6 are many features and commands for SCADA, telemetry, and remote control without having to attach an external sensor. Contact the factory if you wish to use MODBUS commands to control this radio's GPIO.

For many SCADA systems, the GPIO interface is the ideal interface to monitor remote devices or control them. The ones with serial interfaces such as RS-232, USB, and RS485 can be connected to a SCADA controller or HMI to communicate with a remote Tech Series radio modem that has the GPIO interface.

The following commands in the M6 are powerful SCADA and telemetry features.

Command	Command Description	Parameters
FAILSAFE	FAILSAFE A B command sets the minimum message interval, and the default digital output state if an over-the-air MIMIC message is not received within the failsafe period. A is the minimum period in seconds, Set A to 0 to disable FAILSAFE feature. B is the power-on ASCII hex value of the digital outputs, and also B default values are used if the failsafe interval passes and no MIMIC messages are receive. The B values are output again if MIMIC was enabled and no messages received during the MIMIC interval.	A: Required Message Interval or interface to transmit MIMIC data (Seconds) 0 - 99999 B: Default Ascii hex value to set outputs to. 00-FF
MIMIC	MIMIC mode. MIMIC X Y X number of seconds to TX if input 0 is low. X=0 to disable MIMIC mode. Y is number of seconds between transmissions when the input 0 is high.	X: 0-255 Y:0-255
GOUT	GOUT Get the output bit register in hexadecimal format. Example: will return C3 if bits 0, 1, 14, 15 are set(1) and all other clear (0).	Returns Hex value, 16 bits max.
GINP	GINP Get the input bit register in hexadecimal format. Example: will return C3 if bits 0, 1, 14, 15 are set(1) and all other clear (0).	Returns Hex value, 16 bits max.
CBIT	CBIT X Clears output bits, X is hexadecimal format. Any bit in x set to 1 will cause the same output bit in the modem's output register to be cleared to 0. No bits get set. X=C3 to set bits 0, 1, 14, 15. To read the output bit register, enter CLRBIT with no parameter or better to use GOUT command.	0-FF
SBIT	SBIT X Sets output bits, X is hexadecimal format. Any bit in x set to 1 will cause the same output bit in the modem's output register to be set. No bits get cleared. X=C3 to set bits 0, 1, 14, 15. To read the output bit register, enter SETBIT with no parameter or better to use GOUT command.	0-FF
TBIT	TBIT XX MMM Sets output bits for a specific time, XX is hexadecimal format. Any bit in x set to 1 will cause the same output bit in the modem's output register to be set. MMM is in mS. 1000=one second, 60000=one minute,... To set bit #3 to 1 for 250mS: TBIT 4 250 After the time expires, the bits that was st in XX is cleared to 0.	0-FF 2 - 4000000000 (2mS - 1100hours)
TRIGBITS	TRIGBITS This command enables or disables individual bits for use as input triggers.	0-FF
CNTTM	CNTTM B SS Configure a timer to reset the bit's binary counter. B is the bit number (0-15) that is being configured. SS is the interval number of seconds that the transition counter will be reset to 0. Set SS to 0 to never automatically reset the counter.	B: 0 - 15 SS: 0 - 65536
IOPIN	IOPIN XX M Set the GPIO bits on the Tech Series GPIO front panel to inputs or outputs. XX parameter are the hexadecimal representation of the pins being configured. M is the mode for the XX pins. Mode M values: A :Digital TTL Input, B :Digital TTL Output, C :Open Drain MOSFET output, D :DC Power switch output, E :Analog Input	XX=Hex 00-FF M=(A,B,C,D)

Many all of these SCADA commands will work with just the M6 modem module. Some require that the M6 be inside a RV-M22 Tech series enclosure to operate. For example, if there is a desire to have a switched DC output voltage, the RV-M22 Tech Series enclosure must be utilized.

Raveon Technologies Corporation



2320 Cousteau Court
Vista, CA 92081 - USA
Phone: +1-760-444-5995

Version A2

Email: sales@raveon.com
Fax: +1-760-444-5997

Tech Series Flexibility

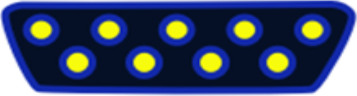
The Tech Series radio enclosure from Raveon is the most flexible radio platform in the industry. 6 I/O options, 6 RF band options, GPS option, wide/narrow channels, Arduino option, and wide DC input voltage range.

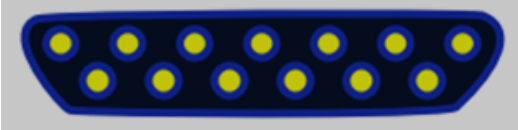
I/O Connector Type	Connector Code
	S
	U
	G, T
	A

Raveon's Tech Series enclosures are the radio modem enclosures referred to as RV-M21 and RV-M22 part numbers. The Series enclosures have many different I/O options:

RS-232[S], USB[U], RS-485[T], RS-422[F], GPIO[G]

MIMIC Mode

The MIMIC mode in the M6 radio module enables two M6's to monitor or remotely control external devices without any additional software or devices. MIMIC mode operation takes the digital inputs from one M6 and automatically transmits them over the air to another M6 that will automatically output them.

Receiving MIMIC messages over the air and outputting them to the I/O pins is done by setting the AT I/O command to 1. If the radio modem used is incorporated into a Tech Series enclosure (M21 or M21), then keep the I/O mode set to 8 (ATIO 8). The MIMIC mode will be enabled automatically when the GPIO front panel of the Tech Series Enclosure is installed on the unit.

Transmitting MIMIC messages: MIMIC transmissions are enabled with the MIMIC X Y command. MIMIC 0 disables MIMIC mode and puts the unit in standard radio modem operation mode. MIMIC X Y with X and Y being any positive number will enable the MIMIC feature. The MIMIC X Y command sets the unit to transmit a MIMIC over-the-air message every X seconds when INPUT0 is low, and to every Y seconds when INPUT0 is high.

If the radio modem is receiving inbound data over the air when it comes time to transmit the MIMIC data, it will wait until the reception is over, and then send the MIMIC data.

Raveon Technologies Corporation

2320 Cousteau Court
Vista, CA 92081 - USA
Phone: +1-760-444-5995

Version A2

Email: sales@raveon.com
Fax: +1-760-444-5997

GPS Tracking Option

The M6 radio module has a GPS option (G) that incorporates a UBLOX GPS module into the module.



The M6 uses Raveon's TDMA protocol to transmit and receive GPS location and status information over the air. Data may also be transmitted in TDMA slots. Using the TDMA protocol, thousands of devices can be tracked with no interference and fast and reliable update times. AES128 encryption is used to secure the location transmissions.

This GPS Transponder lets you quickly locate: your co-workers, your trucks that break-down, your rented watercraft, your stolen vehicle, a drowsy driver, nearest help, lost people, and slow-moving golfers.

It is the fastest real-time GPS tracking transponder available. It uses commercial radio channels without service fees or monthly charges, and it works virtually anywhere.

- Public Safety:** Know where your first-responders and officers are, and who is closest to the scene. See the tactical situation in real-time, so you can respond instead of reacting.
- Vehicle Monitor:** Track vehicles in real-time, monitor speed, door sensors, voltage, and operator behavior. Use the M6 GX for tracking, emergency location, and theft recovery.
- Mining:** Watch your machinery at work, monitoring for improper speed, location, and usage.
- Off-road Racing:** Quickly know where your chase truck and race-car are. Find it fast if it breaks or is stolen.
- Parks and Golf:** Easily locate all other vehicles in the park or golf-course. The location display may be in any vehicle, at the ranger-station, or even with a hand-held GPS.
- Marine:** Track all the vessels in your rental fleet, and ensure they are not abused, stolen, or misplaced. RADAR display can be used to display M6 position AND status.
- Construction:** Know where all your equipment is, and how it is being used. Quickly locate anyone, as soon as you drive onto the site.

GPS location transmit report rates can be setup within the M6 to any update rate from 1 second to 1 day. Transmissions include: Latitude, longitude, speed, heading, altitude, time, temperature, IO status, and motion sensor status.

Raveon Technologies Corporation

2320 Cousteau Court
Vista, CA 92081 - USA
Phone: +1-760-444-5995

Version A2

Email: sales@raveon.com
Fax: +1-760-444-5997