



## The LoRa Protocol

---

By John Sonnenberg

Raveon Technologies Corp

### Overview

---

The LoRa (short for **Long Range**) modulation scheme is a modulation technique combined with a data encoding technique that gives a broad-band spread-spectrum radio the receive sensitivity of a very narrow-band long range radio. Many people are now looking into what is LoRa, and this document describes LoRa and the advantages the LoRa technology has brought to the communication world.

LoRa techniques give LoRa receivers unprecedented sensitivity levels. LoRa radios can receive signals 10 times weaker than most radios.

When a receiver's sensitivity is increased by 10 times, that is the same communication range improvement as increasing the transmitter power 10 times. But with LoRa you get the great range improvements without any increase in power consumption or transmitter power. And most license-free bands restrict transmit power, so LoRa is the best way to increase the communication range of a wireless data link.

Raveon is one of the early implementers of LoRa technology in the USA, and one of the first to get a full-power LoRa device FCC certified. LoRa is a radio modulation technique and protocol that enables a device to have an unprecedented long-range.

### Interference Immunity

---

There are a number of different types of interference all wireless systems must deal with:

- A. **Co-channel interference.** This is where there is some other transmitter on the exact same frequency that the system is currently utilizing. Many RF systems stop working if the interference is even 10dB weaker than the signal being received. With LoRa, the interference can be as much as 19dB larger than the signal being received and the receiver will still get the signal. This means LoRa systems will keep working reliably as the frequency channels get crowded.
- B. **Blocking Rejection.** Sometimes a system needs to operate in a location where there is a powerful interfering signal nearby. For example, in the USA the 906-924MHz ISM band that LoRa uses is only 50mHz away from the 800MHz radio bands where powerful narrow-band transmitters emit 100watts, or 2watt cellular

869-894MHz transmitters. Even though LoRa is 10 time more sensitive, it is even 20 X less susceptible to overload from these powerful out of band signals.

## ***Forward Error Correction***

---

FEC is commonly used to increase a receiver's sensitivity by reducing the bit-error rate of the system. LoRa radios have integrated FEC into the protocol. FEC effectively increases the energy per bit and enables the device to correct for bit errors. By adding extra overhead bits to groups of bits being transmitted, the data throughput gets reduced but the bit-error-rate is lower with weak signals, increasing the sensitivity of the receiver.

## ***Link Margin Comparison***

---

When one compares a LoRa radio system to a traditional UHF or VHF radio modem, we see that the communication range for LoRa is very similar to VHF and UHF, but it achieves this with much less RF power. The spreadsheet calculations below show the theoretical link margin for LoRa 900MHz compared to VHF and UHF radio systems.

	<b>LoRa 200mW</b>	<b>LoRa 10mW</b>	<b>UHF 2W</b>	<b>VHF 2W</b>
Operating Frequency (MHz)	915	915	460	160
Transmitter Output Power	23 dBm	10 dBm	33 dBm	33 dBm
Link Distance, km	180 km	40 km	150 km	450 km
Link Distance, miles	111 mi	24 mi	93 mi	279 mi
Transmit Antenna Gain (dBi)	5	5	3	3
Antenna feed loss (both ends)	1 dB	1 dB	1 dB	1 dB
Receive Antenna Gain (dBi)	5	5	3	3
Receiver Sensitivity	-128dBm	-128dBm	-115dBm	-115dBm
System Gain (dB)	151	138	148	148
Link Fade Margin (dB)	<b>22.2</b>	<b>22.3</b>	<b>22.8</b>	<b>22.4</b>
Link Path Loss (dB)	-136.8	-123.7	-129.2	-129.6
Effective Radiated Power	27	14	35	35

The theoretical calculations show that a 200mW LoRa radio will work about as long-range as a 2watt UHF radio. A 2watt VHF will work a bit longer range but it is using 2 watts. Raveon's field tests support these theoretical calculations. We've seen VHF and UHF reliably go 50-100 miles line of site, and LoRa can easily go 20-50 miles (at 1/10th the power consumption).

As building, forest, and foliage penetration is much better with VHF and UHF radio technology 900MHz systems will typically require taller antennas at the base stations and more base stations to get good coverage. This is offset by the cost and power of LoRa radios being so much lower than traditional VHF and UHF systems so building out large area networks with LoRa is a very good approach.

## LoRa Modulation

---

The over-the-air modulation method that LoRa uses is a type of Direct Sequence Spread Spectrum (DSSS) they call Chirp Spread Spectrum (CSS). Each bit is spread by a chipping factor. The number of chips per bit is called the spread factor. Lora also sweeps the modulation across the channel, so that the occupied bandwidth of the transmitted signal matches the chosen bandwidth.

The larger the spreading factor, the slower the over-the-air data rate. As mentioned before, the slower the data rate, the better the receiver sensitivity and the longer the potential communication range. For an example, here is how a spreading factor of 7 affects the bits sent over the air.

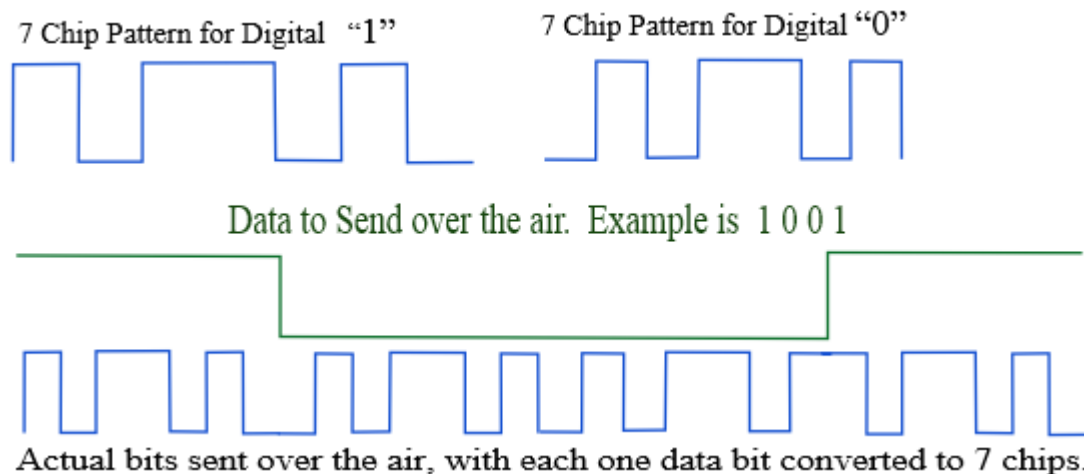

Typically, a LoRa radio uses 125kHz, 250kHz, or 500kHz radio channels. Below is a table showing the over-the-air data rates at the various common spreading factors LoRa uses on these three channel bandwidths.

## LoRa Over the Air (OtA) Baud Rates

---

The OtA data rates listed below are in kilobits per second. This table assumes the LoRa coding chip rate is set to 1.

Spreading Factor	125kHz B.W.	250 kHz B.W.	500 kHz B.W.
5	15.625	31.25	62.5
6	9.375	18.75	37.5
7	5.46875	10.9375	21.875
8	3.125	6.25	12.5
9	1.757813	3.515625	7.03125
10	0.976563	1.953125	3.90625
11	0.537109	1.074219	2.148438
12	0.292969	0.585938	1.171875

## Signal Detection

---

Traditionally, radios use a Radio Signal Strength (RSSI) measurement to detect if there is a signal on the air. Often this is used by sleeping radios to briefly check if they need to wake up and receive a signal.

LoRa uses the channel activity detector (CAD) to detect the presence of a LoRa signal. This is much quicker and more reliable than RSSI methods, so low-power devices with deep sleep modes can save a lot of power and battery life.

## LoRa RF Power Output

---

In the USA, LoRa systems typically use a combination of frequency hopping and direct sequence modes, to keep in compliance with FCC requirements. A hybrid system can use some 125kHz channels and one direct sequence as long as the power limits and dwell limits of the regulations are met.

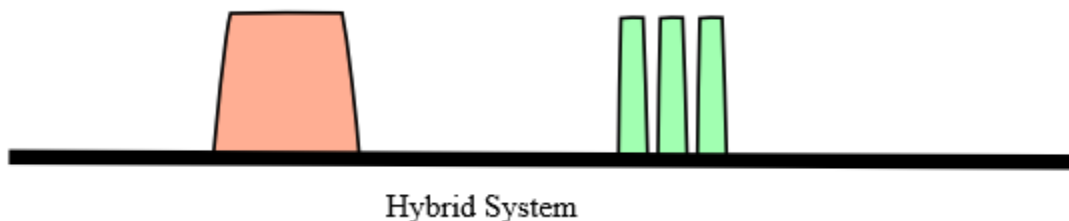

To keep the transmit power level in compliance with the PSD limits, a 125kHz channel has 41 3kHz windows, so the max power is  $41 \times 6.3\text{mW} = 258\text{mW}$  (24dBm). If 500kHz channels are used, then the transmit power can be 4X that (1watt) on the 500kHz channel. To account for modulation peaks and some bandwidth margins, typical LoRa power levels are about  $\frac{1}{2}$  the theoretical limit which will ensure regulatory compliance.

## Multi-Channel

---

Raveon's LoRa base stations utilize LoRa chips that have the ability to receive 8 channels all at the same time. No other long-range wireless technology has this multi-channel receiver capability.

By having the ability to receive 8 channels, 8 wireless nodes can report in at the same time, and as long as they are on different RF channels, the base station can receive them.

## LoRaWAN Frequencies

---

The LoRaWAN protocol specifies that certain frequencies in certain countries shall be supported by every device. These are listed as:

- EU 868.1, 868.3, and 868.5 MHz
- EU 433.175, 433.375 and 433.575 MHz
- China 779.5, 779.7 and 779.9 MHz.
- NA USA 902-928MHz.

## ***Increasing Communication Range***

---

LoRa is usually used in long-range communication systems. There are many ways to increase the range of a communication system, and the LoRa protocol has implemented many of them. The others are something everyone building a wireless data system should consider.

The range of a communication system is determined by:

1. **Antenna gains and antenna heights.**
2. **Transmit power**
3. **Receive sensitivity**
4. **Frequency of the system**
5. **The energy per bit (data rate)**

**Antenna gains** and antenna heights can make huge improvements to the range of a communication system. Antenna performance is one of the most economical ways to improve a system. However antenna gains are sometimes limited by regulatory rules or practical considerations.

The more **transmit power** a device radiates the further away it can be received. In the real world, you must increase power by 4-10 times to double the communication range. Sometimes even a 20 times increase is needed to double the range.

A receiver with good **receive sensitivity** can pick up a signal from much further away than a poor receiver. A receiver that is 4 times (6dB) more sensitive than another receiver will greatly increase the communication range. 6dB receive sensitivity improvement is the same as transmitting 4X more power. But a 6dB better receiver will consume very little additional power. It's always better, cheaper, and more efficient to use a more sensitive receiver than a more powerful transmitter.

Every RF engineer knows the equation for RF communication that shows the higher the **frequency of the system**, the more the loss.

$$L = C + 20 * \log(D) + 20 * \log(F)$$

C is 36.6 if D is measured in miles. L is the free space path loss. You can see that the loss goes up as the distance (D) goes up and as the frequency (F) goes up. If you use a frequency like 900MHz instead of 150MHz, the path-loss is 15dB more. This common formula is often cited as proof that the atmosphere attenuates high frequencies more than lower.

We like to note that the atmosphere doesn't favor 150MHz over 900MHz. The reason the 900MHz system has more loss is that the 900MHz antennas are shorter, so they collect less energy than a 150MHz antenna that is almost 2 meters tall.

The **energy per bit (Eb/No)** is the transmit power divided by the over-the-air data rate. In the 1940s, Claude Shannon determined the communication performance limits for channel coding. He determined that the noise floor, channel bandwidth, and the energy per bit were a fundamental limit to the ability to communicate. To this day, his theorem still stands true. Thus reducing the data rate in half will provide you the same range improvement as doubling your power or doubling your receive sensitivity. Slow data rate radios go much farther than fast radios. It's in the physics of RF. Lora over-the-air baud rates are very slow, typically in the 900 to 22000 bits per second. This is a 100 times slower than WiFi, Bluetooth, or Zigbee but a LoRa radio will have 100 times the Eb/No and 10-100 times their range.

***Raveon Technologies Corporation***

2320 Cousteau Court

Vista, CA 92081

[sales@raveon.com](mailto:sales@raveon.com)

760-444-5995